

BELT CONVEYOR SUPPORT SYSTEM

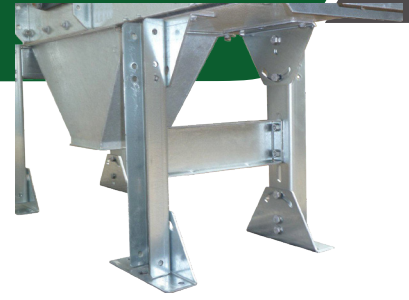

GENERAL

Brand Cimbria
Model Support system belt conveyor GT/GF/GI/GH

Supporting legs for Cimbria belt conveyors are manufactured from galvanized plate. Supporting legs can also be used as suspend (GT, GF).

Drawing shows support system for GT/GF

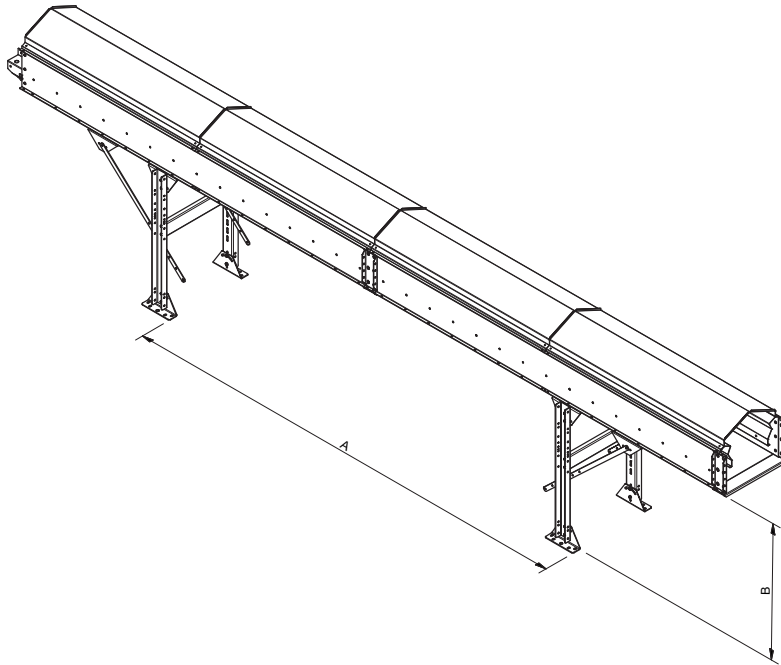

	GT-400 [mm]	GT-500 [mm]	GT-650 [mm]			
A - Max. distance between legs, without Tripper	10 000	10 000	8 000			
A - Max. distance between legs, with Tripper	6 000	6 000	4 000			
B - Max. length of legs	145-2 000	145-2 000	145-2 000			
	GF-400 [mm]	GF-500 [mm]	GF-650 [mm]	GF-800 [mm]	GF-1 000 [mm]	GF-1 200 [mm]
A - Max. distance between legs	6 000	6 000	6 000	6 000	6 000	6 000
B - Max. length of legs	145-2 000	145-2 000	145-2 000	145-2 000	145-2 000	145-2 000
	GI-650 [mm]	GI-800 [mm]	GI-1 000 [mm]	GI-1 200 [mm]		
A - Max. distance between legs	6 000	6 000	6 000	6 000		
B - Max. length of legs	145-2 000	145-2 000	145-2 000	145-2 000		
	GH-650 [mm]	GH-800 [mm]	GH-1 000 [mm]	GH-1 200 [mm]	GH-1 400 [mm]	GH-1 600 [mm]
A - Max. distance between legs, without Tripper	9 000	9 000	9 000	9 000	9 000	9 000
A - Max. distance between legs, with Tripper	4 000	4 000	4 000	4 000	4 000	4 000
B - Max. length of legs	145-2 000	145-2 000	145-2 000	145-2 000	145-2 000	145-2 000