

# GRAVITY SEPARATOR

## GA 110

### GENERAL

|             |                   |
|-------------|-------------------|
| Brand       | Cimbria           |
| Designation | Gravity separator |
| Model       | GA 110            |
| Use         | Industry          |



### Application

Grains or particles of almost identical size are fed continuously on the separating deck surface of the separator, providing a uniform bed of material over the deck surface.

### Design

The deck is fluidised by a completely uniform pressurised air system stratifying the light material to the top of the product bed and allowing the heavy material to contact the deck surface. The deck is inclined from side to side and inlet end to discharge end at adjustable angles.

### Working mode

The deck itself is powered by a well-balanced eccentric drive which moves the deck at low amplitude and high frequency up hill. The heavy material contacting a specially designed square wire deck surface moves up hill, while the light material fluidised by the air system moves down hill due to gravitational pull. A typically separation pattern is depicted below.

1. Intake pre-storage hopper  
For intake adjustment between feeder-elevator and electro-magnetic feeder SP 18 incl. three level indicator switches.  
Delivery with or without supporting legs.
2. Electro-magnetic feeder type SP 18  
For a trouble-free, continuous feeding of the machines.
- 3a. Intake dust-aspiration hopper  
Light dust and fine removals from the product to be cleaned. Connection to central dust exhaust unit.  
Air requirement: 12 m<sup>3</sup>/min, 300 Pa.
- 3b. Partial dust hood  
In case of heavy dust formation, for the removal of dust from the incoming material and the light produce area. Connection to central dust exhaust or individual cyclone and ventilator. Incl. Intake dust-aspiration hopper and frame.  
Air requirement: 170 m<sup>3</sup>/min, 300 Pa.
- 3c. Full dust hood complete closed; suction over the whole table area. With frame.  
Air requirement: 352 m<sup>3</sup>/min, 300 Pa.
- 4a. Discharge hopper for heavy product.
- 4b. Vibrating discharge trough for heavy product with stone trap.
- 5a. Vibrating discharge trough for light product.

- 5b. Bagging-off type hopper for design with base structure (required, if bagging-off type hoppers instead of discharge hopper will be supplied).
6. Cyclofan
7. Exhaust fan  
With motor, without support structure.
8. Dust separating cyclone with rotary valve.

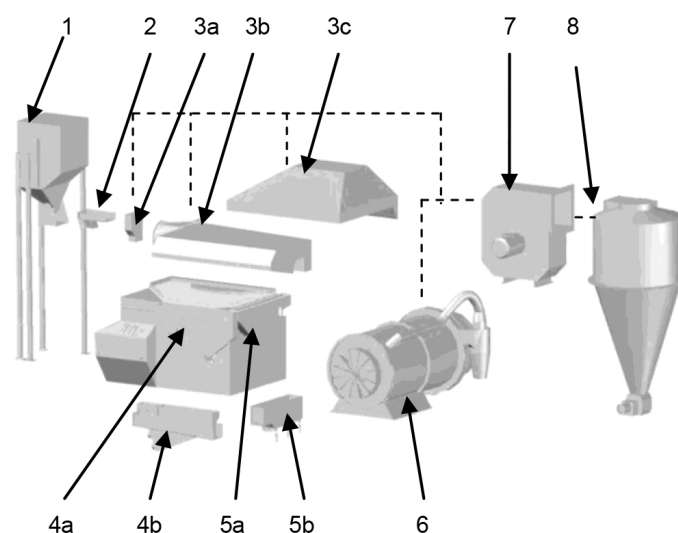

### Technical data

|  |                          |
|--|--------------------------|
| Capacity                               |                          |
| Corn, wheat soybeans                   | 6.5 t/h                  |
| Beans                                  | 3.3 t/h                  |
| Clover                                 | 2.0 t/h                  |
| Coffee (green)                         | 4.3 t/h                  |
| Screen area                            | 2.2 m <sup>2</sup>       |
| Motors: (standard)                     |                          |
| Fan drive                              | 7.5 kW                   |
| Reciprocating drive                    | 1.1 kW                   |
| Air volume:                            |                          |
| Air requirements                       | 300 m <sup>3</sup> /min. |
| Dimensions                             |                          |
| Length                                 | 2 365 mm                 |
| Width                                  | 1 905 mm                 |
| Height                                 | 1 442 mm                 |
| Total weight of separator              |                          |
| Net                                    | 1 370 kg                 |
| Dynamic loading at 7–12 Hz:            |                          |
| PH=+/- 270 N PV=+/- 120 N (10N = 1 kg) |                          |

Technical data can vary for certain of the above due to continued development or a different machine composition.