

# SEA.CX

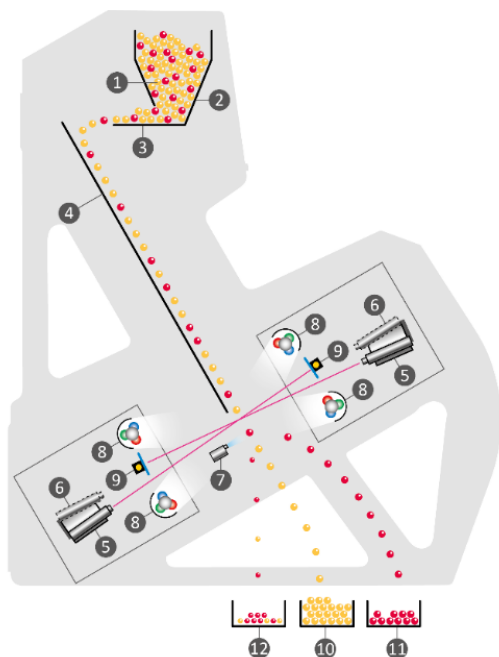

Cimbia's SEA.CX color sorter offers the ultimate Full-Color RGB technology with 0.06 mm optical resolution to meet the most demanding quality standards with respect to seeds, grains, food and non-food commodities



## PROCESS

1. Product to sort
2. In-feed hopper
3. Vibrating feeder
4. Feeding chute
5. RGB Full-Color cameras
6. NIR, InGaAs and UV cameras (option)
7. Ejectors
8. Lights
9. Backlights
10. Sorted flow output
11. Reject flow output
12. Bounce output

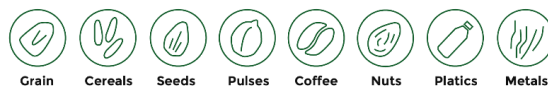

## MAIN CHARACTERISTICS

- Up to 4 sections for simultaneous resorting
- Available configured with re-sorting, re-resorting or reverse sorting
- Image acquisition perfectly conform to reality
- Color analysis like that of the human eye
- Can be controlled and reprogrammed even remotely with the customer's specific recipes

## ELECTRONICS

- Easy-to-replace electronic boards
- Auto-diagnostics and auto-calibration functions ensure operational best performances
- Ethernet connection allows real-time monitoring and remote assistance
- OPC System (option)

## EXPULSION SYSTEM

- N.54 Ejectors per chute
- Ejectors working speed up to 1,000 cycles/s guaranteed up to 2 billion cycles
- Ejection time and duration adjusted according to needs

## OPTICAL SYSTEM

- SEA.CX standard version has RGB Full-color cameras (front and back) with 4096 pixels working in the visible spectrum The inspection system recognizes 16 million colors that combined to 0.06 mm optical resolution sees almost as the human eye
- Additional NIR and/or InGaAs and/or UV cameras (option)
- Scan rate up to 15,000 Hz
- Optical resolution 0.06 mm (60 μm)
- The software controls 14 families of defects
- Shape-sizing integrated into the system
- Defect size control and adjustment
- Active LED light and background

## MECHANICS

- Available from 0.5 to 7 chutes
- Reversible chutes
- Tilting optical boxes simplify cleaning and maintenance
- Pressurization and airtight structure prevent dust entering
- Automatic programmable cleaning system
- Cooling system to grants the ideal temperature inside the optical boxes
- Pre-arrangement for the aspiration system installation

# SEA.CX



## EXAGON HMI

- Windows 10® operating system allows easy use and smart connection to customer networks
- High visibility in low light conditions thanks to its HD 15" full color touch screen
- Intuitive graphics and multilingual interface to program and control recipes in an easy and fast way
- Easily customizable recipes (can store up to 200) named at user's will
- Mark-good mark-bad function
- Out of good programming mode
- Active synoptic system with machine status (vibrators and sensitivity)
- Machine status and control of the production capacity
- Real-time statistics (e.g. rejects/s, throughput, reject/channel and others)
- Data backup

- Product control inside the hopper (level sensors)
- PLC status
- Alarms and instructions to restore functionality

## SEA.CX CONFIGURATION

Front		Back	
T	+	T	Standard version. n.2 RGB Full-Color cameras/chute (front&back)
T	+	TN	n.2 RGB Full-Color cameras/chute (front&back) + n.1 additional NIR camera/chute (in the back-side)
TN	+	TN	n.2 RGB Full-Color cameras/chute (front&back) + n.2 additional NIR camera/chute (front&back)
T	+	TR	n.2 RGB Full-Color cameras/chute (front&back) + n.1 additional InGaAs camera/chute (back-side)
TR	+	TR	n.2 RGB Full-Color cameras/chute (front&back) + n.2 additional InGaAs cameras/chute (front&back)
TN	+	TR	n.2 RGB Full-Color cameras/chute (front&back) + n.1 additional NIR camera/chute (front-side) + n.1 additional InGaAs camera/chute (back-side)

T= RGB Full-Color Camera / N=NIR Camera / R=InGaAs Camera

\* On request, the pre-wired Plus version is available to accept additional cameras in future

## EXTERNAL EQUIPMENT REQUIRED FOR THE CORRECT WORKING\*

- 230VAC - 50/60Hz single-phase power supply
- Voltage stabilizer (strictly necessary)
- Pneumatic system including rotary compressor, tank, filters and dryer
  - ISO 8573-1:2010 [5.4:3] for NON-FOOD PRODUCTS
  - ISO 8573-1:2010 [1.2.1] for FOOD PRODUCTS
- 1" minimum diameter air supply hose
- Supporting frame (Minimum one meter of free space each sides)
- Infeed and discharging hoppers (optional Cimbria supply)
- Product conveyors systems
- Fast internet connection

\*Customer must provide and install the above

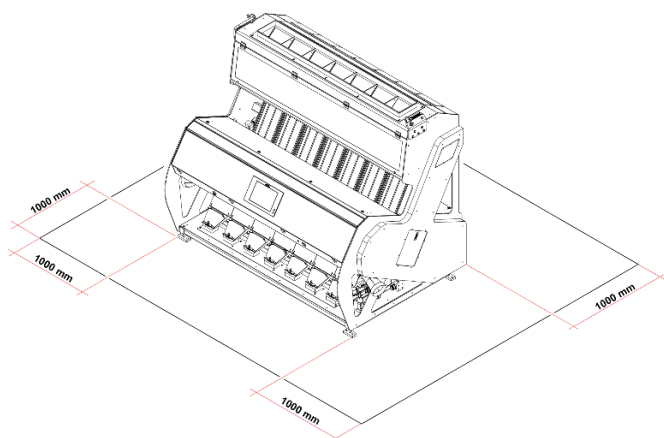









Leave at least one meter of free space around the sorter

## TECHNICAL DATA

- White RAL 9003 Standard (custom colors as option)
- Working temperature in workrooms min +5°C max+35°C
- IP 55 protection
- CE conformity certificate
- 2006/42/CE on machinery safety
- 2014/30/CE on Electromagnetic Compatibility
- Compatible with UL and CSA standards
- ATEX standards Certificate (option)
- Sorting machine in stainless steel AISI 316 L (option)

## MACHINE TECHNICAL DATA

		0,5	1	1,5	2	3	4	5	6	7
										
No. of vibrating feeders/chutes		1	1	1,5	2	3	4	5	6	7
No. of cameras (front+back)		2	2-4	2-4	4-8	6-12	8-16	10-20	12-24	14-28
No. ejectors/chutes		27	54	77	108	162	216	270	324	378
Compressed air consumption (max value at 6 bar)	l/min	150	300	450	600	900	1200	1500	1800	2100
	m <sup>3</sup> /h	9	18	27	36	54	72	90	108	126
Compressed air hose	∅	1"								
Power supply/frequency	V/Hz	230VAC - 50/60Hz - 1 Ph (L + N + PE)								
Power consumption (max. value)	KW	0,8	0,8	0,8	1,5	1,5	2,3	2,3	2,7	2,7
Power absorption (max. value)	A	3,1	3,1	3,1	6,4	6,4	9,7	9,7	11,8	11,8

## ASPIRATION SYSTEM

	0,5		1		1,5		2		3		4		5		6		7	
	m <sup>3</sup> /h	l/min	m <sup>3</sup> /h	l/min	m <sup>3</sup> /h	l/min	m <sup>3</sup> /h	l/min	m <sup>3</sup> /h	l/min	m <sup>3</sup> /h	l/min	m <sup>3</sup> /h	l/min	m <sup>3</sup> /h	l/min	m <sup>3</sup> /h	l/min
Extraction	500	8333	500	8333	500	8333	1000	16667	1000	16667	2000	33333	2000	33333	3000	50000	3000	50000

\* The user must ensure, near the intake vents, an air head equal to 150 mm H<sup>2</sup>O

\*\*Minimum flow values required to the machine to process a highly polluted product

## DIMENSIONS (mm/in)

	0,5		1		1,5		2		3		4		5		6		7	
	mm	in	mm	in	mm	in	mm	in	mm	in	mm	in	mm	in	mm	in	mm	in
Length	935	36,81	935	36,81	935	36,81	1510	59,44	1510	59,44	1915	75,39	1915	75,39	2465	97,04	2465	97,04
Width	1690	66,53	1690	66,53	1690	66,53	1690	66,53	1690	66,53	1690	66,53	1690	66,53	1690	66,53	1690	66,53
Height	2100	82,67	2100	82,67	2100	82,67	2100	82,67	2100	82,67	2100	82,67	2100	82,67	2100	82,67	2100	82,67

## WEIGHT (Kg/lbs)

	0,5		1		1,5		2		3		4		5		6		7	
	Kg	lbs	Kg	lbs	Kg	lbs	Kg	lbs	Kg	lbs	Kg	lbs	Kg	lbs	Kg	lbs	Kg	lbs
Weight	700	1543	750	1653	800	1764	1000	2205	1060	2337	1250	2756	1300	2866	1600	3527	1650	3638